LURE OF THE NORTH



Handcrafting Traditional Winter Moccasins Book 2: Canvas Uppers



Kielyn and Dave Marrone
Version 3.0 April 2019
<https://lureofthenorth.com>

Note: This booklet is a continuation of a larger moccasin making series. For all other publications in this series, please see our website at lureofthenorth.com. Published instructional booklets can be found under "Info Hub" in the main navigation menu.

Booklets in the Winter Moccasins Series

Book 1: Lowers;

Book 2: Tube-style canvas uppers (this booklet);

Book 3: Wrap-style buckskin uppers using boar, deer or other buckskin;

Note 1 - Acknowledgements: The original impetus for these instructions came from Garrett and Alexandra Conover's excellent book "A Snow Walker's Companion". They are an inspiration in this field.

Note 2 – Lure Moccasin Making Kits: These instructions are intended to be accompanied by our Moccasin Making Kit, which is available through the “Store” section of our website at: <https://lureofthenorth.com>. Of course, you can also gather all materials yourself and simply use these instructions as a guide, modifying to suit your requirements.

Note 3 - Distribution: Feel free to distribute these instructions to anyone you please, with the requirement that this package be distributed in its entirety with no modifications whatsoever. Thanks!

Note 4 – Feedback and Further Help: Feedback is welcomed to improve clarity in future editions. For even more assistance you might consider taking a moccasin making workshop with us. These workshops are run throughout Ontario, and includes hands-on instructions and all materials. Again, check the website for more details and a current schedule.

Our Philosophy: This booklet describes our understanding of a traditional craft – these skills and this knowledge has traditionally been handed down from person to person and now we are attempting to do the same. We are happy to have the opportunity to share this knowledge with you, however, if you use these instructions and find them helpful, please give credit where it is due. We have worked hard to produce this package and would appreciate any acknowledgements given. Thank you.

- The Lure Team, Kielyn & Dave Marrone

Version 3.0, April 2019
<https://lureofthenorth.com>

Table of Contents:

0.0 About the Canvas, Tube-Style Uppers.....	4
1.0 Getting Prepared.....	5
1.1 Material Requirements.....	5
1.2 Tool Requirements.....	6
1.3 Insulating Layers.....	6
2.0 Trim Your Lower Vamp.....	6
3.0 Measure and Cut your Uppers.....	7
4.0 Decorate.....	8
5.0 Button-hole.....	9
6.0 Add LOTN Logo.....	10
7.0 Complete the Tube.....	10
8.0 Create the Upper Tunnel.....	10
6.0 Attach Upper to Lower.....	11
7.0 Adding Fur.....	14
8.0 Final Words.....	15
Appendix 1: Pattern.....	16



0.0 About the Canvas, Tube-Style Uppers

The canvas, tube-style upper is the classic upper style described in the Conover's "A Snow Walker's Companion", and probably the style most often seen on winter moccasins these days. In this design the upper is sewn into a tube, and pulled on over the foot and calf just like a modern boot.

Canvas is a fantastic option for uppers as it is:

- economical;
- lightweight;
- durable;
- breathable;
- practically wind-proof;
- quick-drying; and
- easy to customize with the use of ribbon and/ or fur.



Illustration 1: A typical wrap-style upper with decorative ribbon

However, being a woven fabric, it does require finished edges, which are most easily done with a sewing machine, and it is less traditional than buckskin uppers. For those that want to make their moccasins in the field without a sewing machine, want a more traditional product, or simply prefer the look of a wrap-around style upper, please see the third booklet in this series entitled "Buckskin Uppers"



Illustration 2: Celebrating Completion of our Explorer's Club 2016

1.0 Getting Prepared

1.1 Material Requirements

Canvas, “tube-style” uppers require the following materials:



Illustration 3: All the materials needed to make the finished upper.

- A completed pair of moccasin lowers (see booklet 1 in this series);
- 36” x 24” piece of 10oz. cotton canvas;
- 4’ of decorative ribbon;
- 4’, light cotton tape for binding bottom edge of canvas;
- 2 x 3/8” x 50” light cotton webbing used as upper ties, ends sealed with beeswax;
- 2 x 3/8” x 9’ light cotton webbing uses as wrap-around ties, ends sealed w/ beeswax;
- Artificial sinew – enough for project, plus extra for repair kit;
- 2x “Glover’s Needles” (aka. “Triangular Needles” or “Leather Needles”);
- Lure of the North logo patch;
- These instructions.

1.2 Tool Requirements

- A regular household sewing machine with regular thread and denim needle;
- pins;
- scissors;
- measuring tape;
- ruler;
- large safety pin;

1.3 Insulating Layers

You should have all your insulating layers on hand to properly size your uppers. Insulating layers are covered in more detail in booklet 1 of this series.



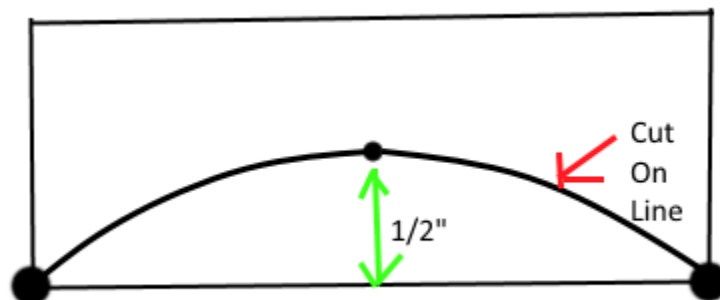

2.0 Trim Your Lower Vamp



1. Grab your lower moccasin;
2. Lay the vamp flat;
3. From side tack to side tack, draw an imaginary line straight across and find centre;
4. From the centre measure straight up half an inch;

5. Draw a curved line and cut. This curve allows for the moccasin to lay nicely on the rise of your foot.

3.0 Measure and Cut your Uppers

The Three Key Measurements		
		
<p><i>Illustration 4: "A" Ankle Measurement</i></p>	<p><i>Illustration 5: "C" Calf Measurement</i></p>	<p><i>Illustration 6: "H" Height</i></p>

Write all measurements on a piece of paper. Remembering to divide the "A and C" in half since you'll be folding the canvas in half.

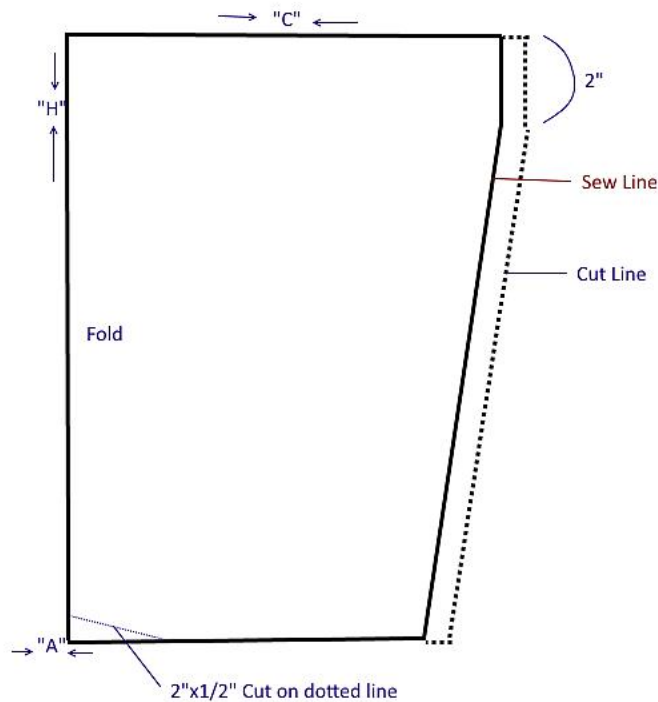

Illustration 7: Upper Pattern- HALF "A and C" measurements

1. Measure the distance around the ankle opening of your moccasin lowers. Try not to stretch the hide as you take your measurement. Allow the tape to naturally follow the hide.
 - a) **Note:** It is quite likely your two moccasin ankles will be different sizes (this is the reality of handcrafts, and not an issue). This means that each moccasin will have an upper created specifically for it. Take each different "A" measurement and create a custom upper. Be sure to identify your lower and upper pairings so that you can match them up correctly when it comes time to join the pieces.
2. **While wearing your boot liners**, measure the height of your lower leg, from the top of your moccasin lower to the desired top of your finished moccasin (usually just above the calf). Add 1" to this measurement. This is "H" on your pattern.
3. **Still wearing your insulating layers** measure a comfortable diameter around the widest part of your calf. This should be comfortably loose around your insulating layers to allow you to pull your finished moccasin on and off. The best way to ensure a good final fit, is to form the measuring tape into a loop of estimated diameter and try pulling it on and off your foot. It should go on easily without being sloppy.
4. Fold your piece of canvas in half in a way that lets you cut both uppers out; Pin together.
5. Mark your measurements on your piece of canvas but divide each measurement in HALF;
6. From the top of your "H" draw a line Straight down for 2"- This will allow for a better roll down seam.
7. Mark another line 1/2" larger from your actual measurements. This will be your seam allowance.
8. Cut your pattern.
9. Draw the small "Foot Contour" seen in the template. On an averaged size upper, this should be about 2" wide and 1/2" tall. Snip this small triangle of material off.
10. Unpin, and unfold. Your finished, cut upper, should be twice the width of your pattern piece and fit comfortably around your calf.
11. Repeat for the second upper. **Remember:** If you have significant ($> 1/2"$) differences in the ankle openings of your moccasin lowers, you will be creating two slightly different uppers, and should discreetly label them as such so they can be joined to their proper pair later.

4.0 Decorate

In this step you will pin on the decorative portions of the gaiter. The central ribbon is entirely optional. The purpose of the lower bias tape is to finish the open canvas seam here to ensure it does not fray.

1. Cut bias tape long enough to span bottom (ankle) edge of unfolded canvas +1 inch for grace ;
2. Pin the bottom bias tape in place:
 - a) Fold the bias tape in half over the bottom edge of the canvas and pin.
 - b) Because the canvas is not straight at its bottom edge (having a dip at the foot contour) you are



Illustration 8: A properly pinned upper

trying to force the bias tape into a line it would not naturally take... use care and lots of pins here to force the bias tape into following smooth curves along the bottom edge of the canvas.

- c) Ensure you have folded the bias tape fully over the edge of the fabric, so that when you sew, your stitches will bite into lots of canvas. Take your time. If your bias tape is only over a tiny edge of canvas, then the canvas will fray and your bias tape will pull off.
3. Pin the upper decorative ribbon in place approximately $\frac{2}{3}$ - $\frac{3}{4}$ of the way up the canvas (if you're adding fur you will want it slightly lower). This should be on the "right" side of your canvas (ie. the side without all the pen or pencil marks placed previously).
 - a) Fold the canvas in half and mark on both halves of the canvas where you intend the ribbon to meet.
 - b) Because the ribbon is following a straight line, fewer pins are required.
 - c) After pinning the ribbon, fold the canvas in half again and double check that the ribbon will meet itself properly once you sew your canvas into a tube, otherwise this will be a visible cosmetic flaw at the back of your moccasin later where these ribbons do not meet each other.
4. Using your sewing machine on a straight stitch, sew the lower bias tape onto each of your gaiters.
5. Again with the sewing machine on a straight stitch, sew down the upper decorative ribbon.

5.0 Button-hole

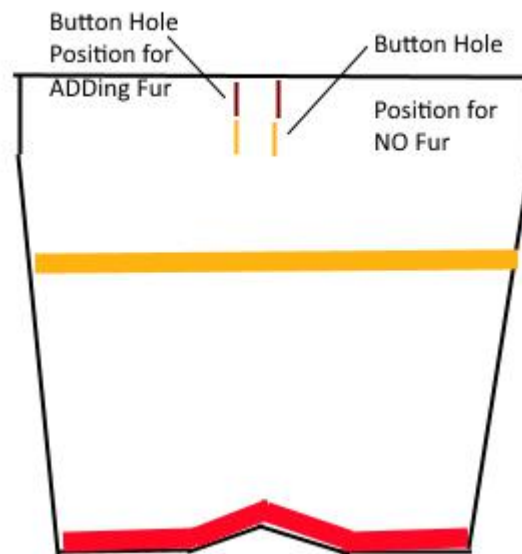

Illustration 9: Button Hole Position

1. Cut two button holes $\frac{3}{4}$ " tall in the front of your gaiter approximately $\frac{1}{2}$ " off centre on either side and starting 1" down from the top of your liner. NOTE: If you are planning to add fur to your uppers then the button holes should be placed right at the top of your uppers. This will

mean that the button-hole is on the inside of your upper so that the fur doesn't interfere with tightening the upper.

2. Hand sew these button holes using your sinew, a regular needle and the whip stitch. A 'button-hole' or 'blanket-stitch' can be used here to slightly nicer effect, but in the interest of simplicity the whip stitch will work just fine. *Sewing your button holes is necessary in the canvas to prevent fraying.*

Note: If you know how to use your button-holer then go for it! Otherwise the hand stitching works fine as well.

6.0 Add LOTN Logo

Because you're awesome! We usually put it near the back and just above the decorative ribbon if you're not adding fur and just below the ribbon if you are.

7.0 Complete the Tube

1. Fold you gaiters inside-out, along the pattern's original fold line. Pin in this position.
2. Using a straight stitch, sew along the sew line.
3. Using a tight (short), wide zig-zag stitch, sew right next to the straight stitch- to the outside of the upper.

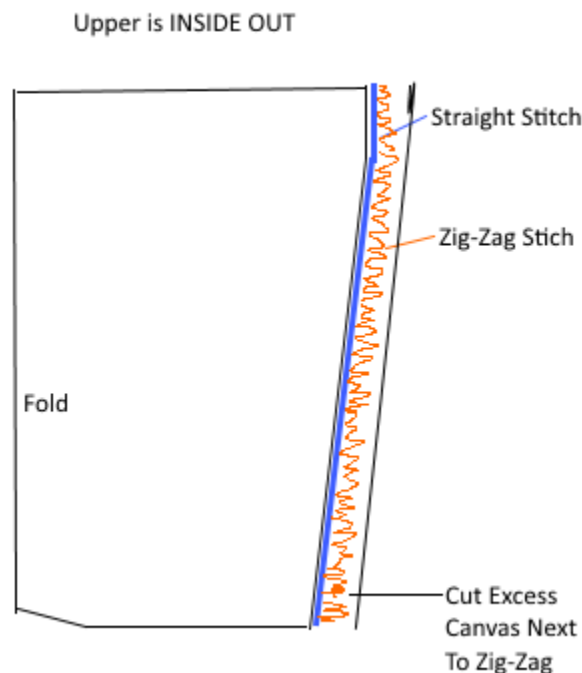

Illustration 10: Sewing Into a Tube

Your standard gaiter is now a decorated tube! All that remains is to create a tunnel for your top ties!

8.0 Create the Upper Tunnel

It is important that this section occurs after the moccasin has been sewn into a tube (which you did in the previous section). If done correctly you will have a continuous upper tunnel which goes all the way around the moccasin. Intuitively, many prefer to do this step earlier, but you will end up cutting this tunnel in half when you sew your tube seam if done this way.

As this tunnel is formed right at the mouth of your tube, you should have no issue getting this to work on most any sewing machine.

1. Fold ~1" of the top of the canvas down inside the gaiter.
 - a) This will be the width of the tunnel through which you will run your upper tie. Tuck just the edge under the roll-down so that you will have a finished seam and pin it in place.
3. Using a straight stitch, sew all the way around the edge of the tunnel.
4. Thread your upper ties!
 - a) Use a large safety pin ('blanket pin') to thread your upper ties through your newly created tunnel. If you are using cotton ties as I usually do, the best way to seal the edge is by dipping it in beeswax (Lure kits come with pre-waxed ties). If you are using a synthetic tie, you can seal the edge by melting it together.



Illustration 11: The finished button holes

Your uppers are now complete. You are in the home stretch. Put the upper on, slip your lowers back on, and strut your stuff. Resist the urge to duct tape the two parts together and go for a walk – it will come soon enough!

6.0 Attach Upper to Lower

This step can be a bit confusing - lots of photos should help out here!

1. Remember that in Section 3 you may have labeled your uppers and lowers if the ankle seams on your lowers were different lengths. If this was the case, be sure to match up the proper lower with the proper upper at this point.
 - a) **Note:** Before beginning to attach your uppers and lowers, you should always do a 'dry run' to test the fit. That is, place the rear seam of the upper against the rear of the lower and run your hand along both seams to ensure they line up properly. If your uppers are slightly bigger than your lowers, this is completely fine – you can stretch the deerskin lowers somewhat to match perfectly with the canvas upper. If your lowers are slightly bigger than your uppers, you will not be able to stretch uppers to accommodate, however a few discrete puckers in the lower may save the day. If the uppers and lowers are significantly different, you can add or remove some stitches from the lower to adjust the ankle opening to match the upper.

2. Turn both the upper and the lower inside-out.

3. Align the upper and lower.

- a) This step is hard to describe, but if followed properly creates a nice hidden seam where the upper and lower attach.
- b) Align the upper and lower, so that the upper is inside the lower. I.e. the inside (or 'wrong' side) of the upper should be against the outside (or 'right' side) of the lower. The binding tape at the bottom of the gaiter, should hang just slightly below the upper edge of the lower.
- c) Fold the upper down, so that you form a bight, or bend of canvas, flush with the top edge of the deerskin.
- d) Line up the rear seam on the canvas with the rear seam on the deerskin. Do a tack there: Remember- 3 x Through and the Loop 'D' Loo. This is just to ensure your alignment on both sides match.



Illustration 12: Aligning the Upper and Lower

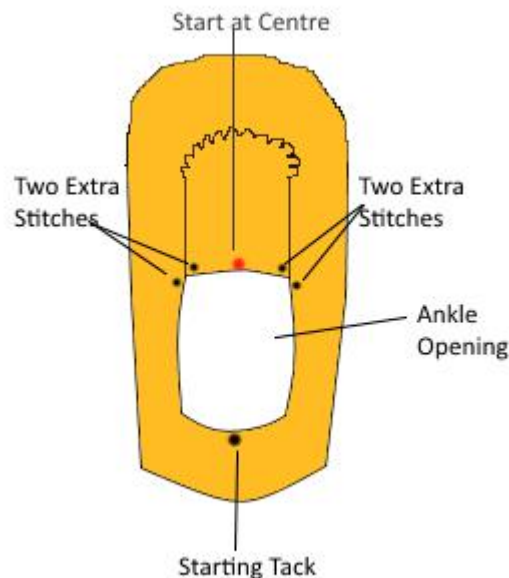

Illustration 13: Upper Alignment and Stitching Reinforcement

4. Starting at the centre of the vamp, whip-stitch toward through 2 layers of canvas, and 1 layer of deer. **Pull hidden seam on the outside of your finished moccasins. These stitches, the seam will be more visible with use.**

- a) It is easy to confuse this step and install your gaiter on inside-out, or hanging inside your moccasin instead of on the outside of the



Illustration 14: Double check after the first few stitches!

moccasin. If this happens, it is an easy matter to pull stitches out and start again. To avoid going too far, after you have made 6 – 8 stitches, open your project up, turn everything right-side-out and look at how things are laying. The ribbon on your canvas upper should hang just below (and cover) the top edge of your deerskin lower. The seam which you are creating in attaching the two parts should be hidden inside a fold of canvas (provided adequate tension in the stitches).

5. Continue whip-stitching around the ankle but check to see how your upper and lower are lining up. If one is larger than the other, you can over time stretch or pucker them so that you don't end up with a big pucker at the back. Spread out any inconsistencies.
6. Once you get to the back tack, finish it off with your 3 x through and loop 'd' loo.
7. Start back at the centre of the vamp and head the other way remembering to reinforce at the corner of the vamp.
8. Turn everything right-side-out. Your moccasins are almost finished!
9. Thread your wrap-around lace through the tab you have installed at the rear of your moccasins. Slip on all your insulating layers, slide in your insole, and put on your finished product. Prance around a little. Do a jig. If you are lucky enough to do this in the winter, then play in the snow. Things will probably feel quite tight right now, especially if you have your insole in, but the deerskin will relax.
10. Enjoy!

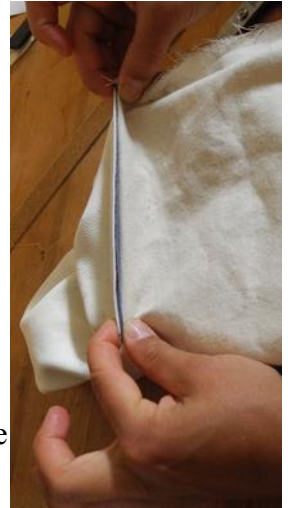

*Illustration 15:
Checking the
alignment in the
'home-stretch'*



*Illustration 16: Our finished moccasin.
Congratulations on your own!*

7.0 Adding Fur

1. Turn moccasin INSIDE OUT;
2. Place fur with the hair direction running down, skin facing out, lined up with the top edge of the moccasin upper.

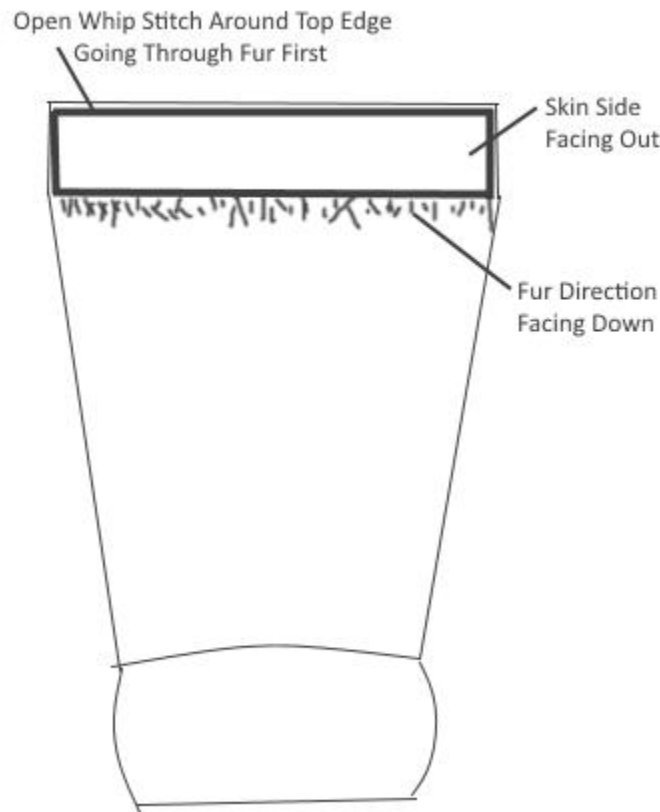

Illustration 17: Adding Fur

3. Whip stitch all the way around the top cuff of the moccasin upper. Go down through the skin first so that the needle doesn't pull the hair through every stitch;
4. Once you get around, using a knife, slice the fur on a slight angle so that it doesn't tighten the cuff up when you flip it;
5. Whip stitch the two layers of fur together so that it is a completed tube of fur;
6. Flip the whole moccasin right side out;
7. Do 5 or 6 tacks around the edge by pulling the fur up so you're missing the long hairs. The tack will be covered by the fur when you let go.

That's it! Now you have beautiful fur on your moccasins!

8.0 Final Words

Now that your mocs are done, its time to get out and use them! At Lure of the North we are passionate about making aesthetically beautiful, natural handcrafts. But all of our items are also designed to be functional gear that can be used in the bush. There is no better way to truly appreciate your new craft than getting out and using them, so please, tie them on your feet, and take a hike!



Congratulations on your finished moccasins!!

Thank you so much for your support!

If you are happy with these instructions and our kits please spread the good word on Facebook, Instagram and Youtube.

You can follow us:

[@lureofthenorth](#)

For more information please see our website:

www.lureofthenorth.com

Appendix 1: Pattern

